

1-1658624-0 ✓ ACTIVE

AMP-LATCH | AMP-LATCH - NOVO

TE Internal #: 1-1658624-0

Ribbon Cable Connectors, Wire-to-Board, 50 Position, 2.54 mm [.1 in] Centerline, Vertical, Through Hole - Solder, AMP-LATCH - NOVO

[View on TE.com >](#)



Connectors > PCB Connectors > Wire-to-Board Connectors > FFC, FPC & Ribbon Connectors > Ribbon Cable Connectors

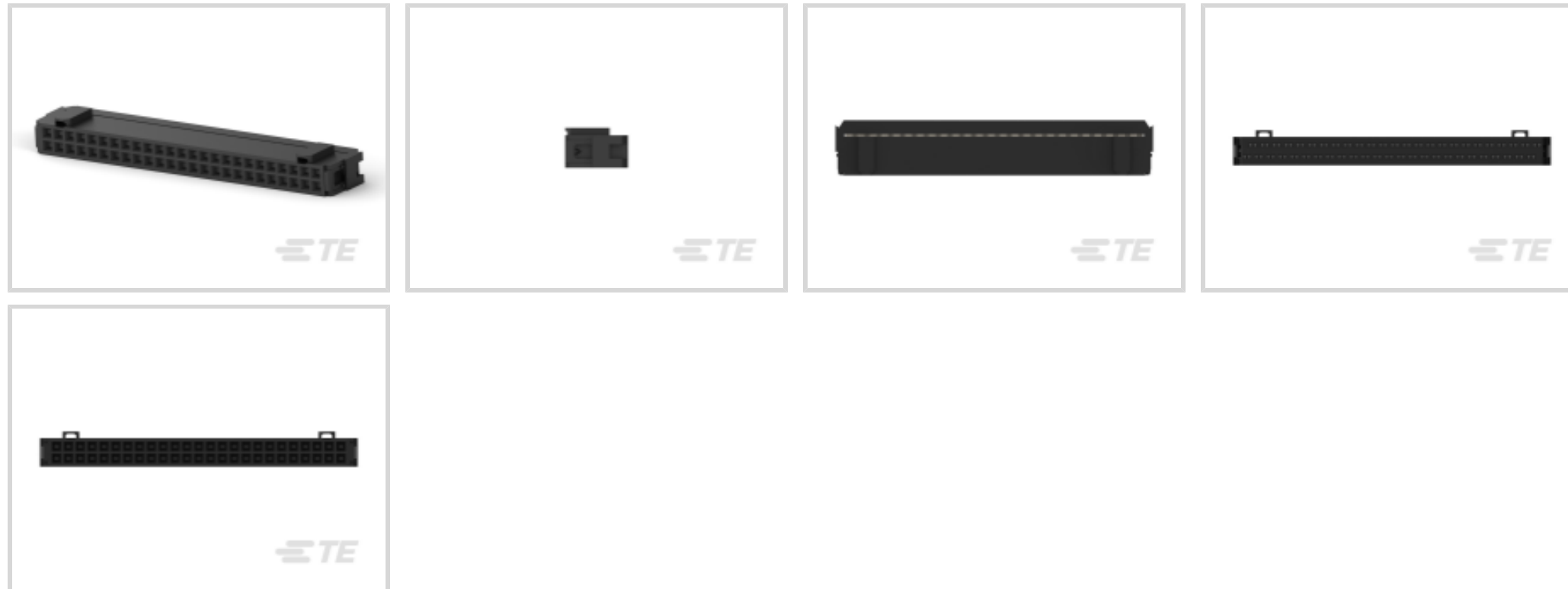

Connector System: **Wire-to-Board**

Number of Positions: **50**

Centerline (Pitch): **2.54 mm [.1 in]**

PCB Mount Retention: **Without**

PCB Mount Orientation: **Vertical**

Features

Product Type Features

Connector Type	Connector Assembly
Ribbon Cable Connector Header Type	Pin Header
Connector Product Type	Connector Assembly
Connector System	Wire-to-Board
Connector & Housing Type	Receptacle
Connector & Contact Terminates To	Wire & Cable

Configuration Features

Compatible With Wire & Cable Type	Ribbon Cable
Number of Positions	50
PCB Mount Orientation	Vertical
Number of Rows	2

Electrical Characteristics

UL Voltage Rating	250 VAC
Insulation Resistance	5000 MΩ



Operating Voltage	250 VAC
-------------------	---------

Body Features

Daisy Chain	Without
Connector Profile	Low

Contact Features

Mating Square Post Dimension	.64 mm[.025 in]
Mating Pin Diameter	.64 mm[.025 in]
Contact Type	Socket
Wire Contact Termination Area Plating Thickness	1.27 μ m[50 μ in]
Wire Contact Termination Area Plating Material	Tin
Contact Mating Area Plating Material Thickness	.76 μ m[29.92 μ in]
Contact Mating Area Plating Material	Gold, Gold Flash over Palladium Nickel
Contact Shape & Form	Tuning Fork
Contact Underplating Material	Nickel
Contact Base Material	Phosphor Bronze
Contact Current Rating (Max)	1 A

Termination Features

Termination Method to Printed Circuit Board	Through Hole - Solder
Termination Method to Wire & Cable	Insulation Displacement (IDC)

Mechanical Attachment

Mating Alignment	With
PCB Mount Alignment	Without
Panel Mount Feature	Without
PCB Mount Retention	Without
Mating Alignment Type	Polarization
Mating Retention	Without
Connector Mounting Type	Cable Mount (Free-Hanging)

Housing Features

Housing Material	Thermoplastic
Housing Color	Black
Centerline (Pitch)	2.54 mm[.1 in]

Dimensions



Connector Length	68.07 mm[2.68 in]
Connector Height	15.16 mm[.597 in]
Connector Width	7.49 mm[.295 in]
Wire Size	.08 – .15 mm ²
Accepts Wire Insulation Diameter Range	.79 – .94 mm[.031 – .037 in]
Row-to-Row Spacing	2.54 mm[.1 in]

Usage Conditions

Operating Temperature Range	-65 – 105 °C[-85 – 221 °F]
-----------------------------	----------------------------

Operation/Application

Circuit Application	Signal
---------------------	--------

Industry Standards

CSA File Number	LR 7189
UL Rating	Recognized
UL File Number	E28476
Agency/Standard	CSA, UL
UL Flammability Rating	UL 94V-0

Packaging Features

Packaging Quantity	50
Packaging Method	Box & Tube, Tube

Product Compliance

[For compliance documentation, visit the product page on TE.com>](#)

EU RoHS Directive 2011/65/EU	Compliant
EU ELV Directive 2000/53/EC	Compliant
China RoHS 2 Directive MIIT Order No 32, 2016	No Restricted Materials Above Threshold
EU REACH Regulation (EC) No. 1907/2006	Current ECHA Candidate List: JUNE 2022 (224) Candidate List Declared Against: JUNE 2022 (224) Does not contain REACH SVHC
Halogen Content	Not Low Halogen - contains Br or Cl > 900 ppm.
Solder Process Capability	Not applicable for solder process capability

Product Compliance Disclaimer

This information is provided based on reasonable inquiry of our suppliers and represents our current actual knowledge based on the information they provided. This information is subject to change. The part numbers that TE has identified as EU RoHS compliant have a maximum concentration of 0.1% by weight in homogenous materials for lead, hexavalent chromium, mercury, PBB, PBDE, DBP, BBP, DEHP, DIBP, and 0.01% for cadmium, or qualify for an exemption to these limits as defined in the Annexes of Directive 2011/65/EU (RoHS2). Finished electrical and electronic equipment products will be CE marked as required by Directive 2011/65/EU. Components may not be CE marked. Additionally, the part numbers that TE has identified as EU ELV compliant have a maximum concentration of 0.1% by weight in homogenous materials for lead, hexavalent chromium, and mercury, and 0.01% for cadmium, or qualify for an exemption to these limits as defined in the Annexes of Directive 2000/53/EC (ELV). Regarding the REACH Regulation, the information TE provides on SVHC in articles for this part number is based on the latest European Chemicals Agency (ECHA) 'Guidance on requirements for substances in articles' posted at this URL: <https://echa.europa.eu/guidance-documents/guidance-on-reach>

Compatible Parts

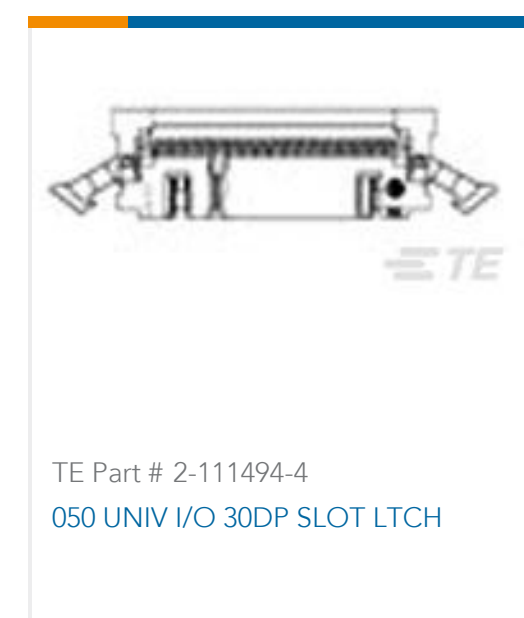

Also in the Series | AMP-LATCH - NOVO



Ribbon Cable Connectors(46)



Ribbon Connector Accessories(10)

Documents

Product Drawings

050 NOVO DUAL 30DP FT

English

CAD Files

Customer View Model

ENG_CVM_CVM_1-1658624-0_D.2d_dxf.zip

English

3D PDF

3D

Customer View Model

ENG_CVM_CVM_1-1658624-0_D.3d_igs.zip

English

Customer View Model

ENG_CVM_CVM_1-1658624-0_D.3d_stp.zip

English

By downloading the CAD file I accept and agree to the [Terms and Conditions](#) of use.

Datasheets & Catalog Pages

Ribbon Cable Interconnect Solutions

English

Product Specifications

Application Specification

English

Instruction Sheets

Instruction Sheet (U.S.)

English

Agency Approvals

Agency Approval Document

English